

# WATERMAN STEM GUIDES

**FEATURES:**

- Cast Iron or Fabricated Mild or Stainless Steel
- Plain or Bushed
- Metallic or Non-Metallic Bushings
- Solid or Split Types
- Reach from 2" to 48"
- For Stems Sized 7/8" to 6"
- Adjustable in 2 Directions
- Custom Guide Brackets are Available

**TYPICAL SPECIFICATION:**

Stem Guides shall be heavy cast iron (fabricated mild steel) (fabricated stainless steel) with bronze (non-metallic) bushings, and shall be mounted to heavy cast iron mounting brackets. Guides shall be adjustable in two directions and shall be so constructed that when properly spaced, they will hold the stem in alignment and still allow enough play to permit easy operation. Stem guides shall be spaced per the recommendations of the manufacturer, but in no case shall spacing exceed an l/r ratio of 200. Brackets shall be attached to the wall by anchor bolts of sufficient strength to prevent twisting or sagging under load.



K-2 Stem Guide

MAXIMUM RECOMMENDED STEM GUIDE SPACING																	
L/R 200																	
Dia. (inches)	7/8 S	7/8 T	1 S	1 T	1 1/8 S	1 1/8 T	1 1/4 S	1 1/4 T	1 1/2 S	1 1/2 T	2 S	2 T	2 1/2 S	2 1/2 T	3 S	3 T	
Spacing (inches)	43 3/4	34 3/4	50	41	56 1/4	47 1/4	62 1/2	53 1/2	75	66	100	91	125	116	150	141	
S = Solid T = Threaded																	

**WATERMAN STEM GUIDES  
TYPICAL DIMENSIONS**

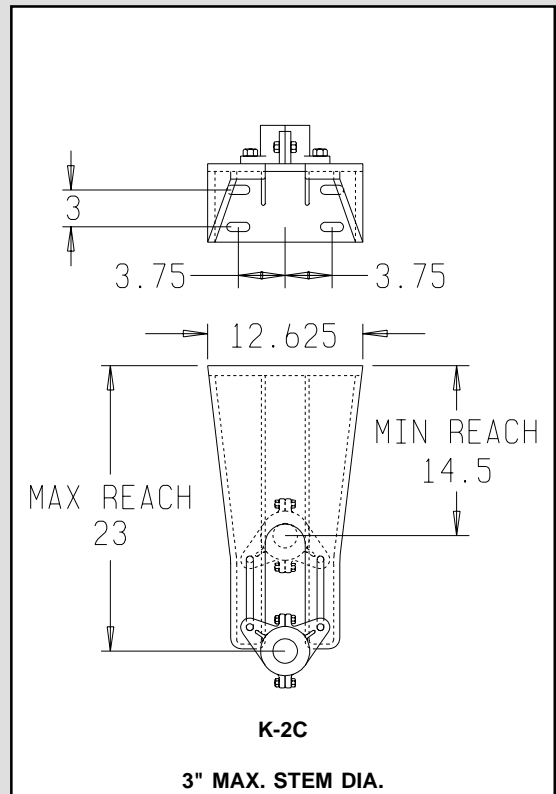
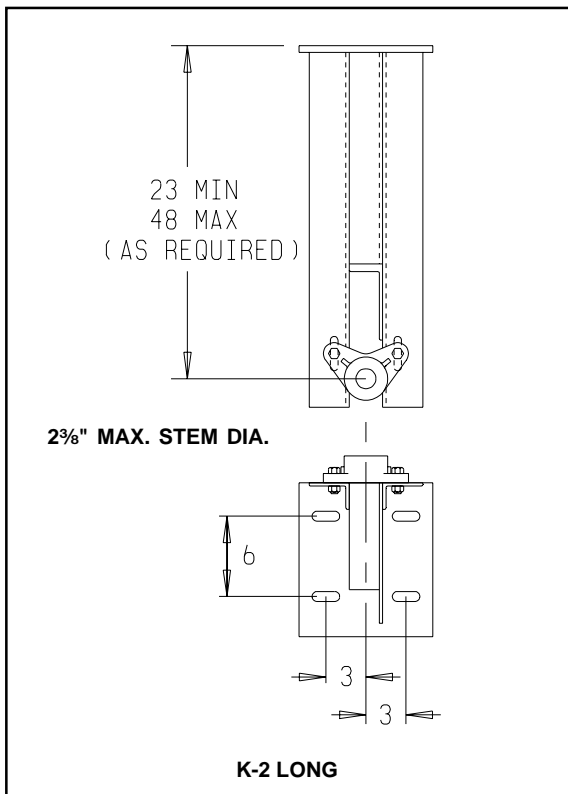
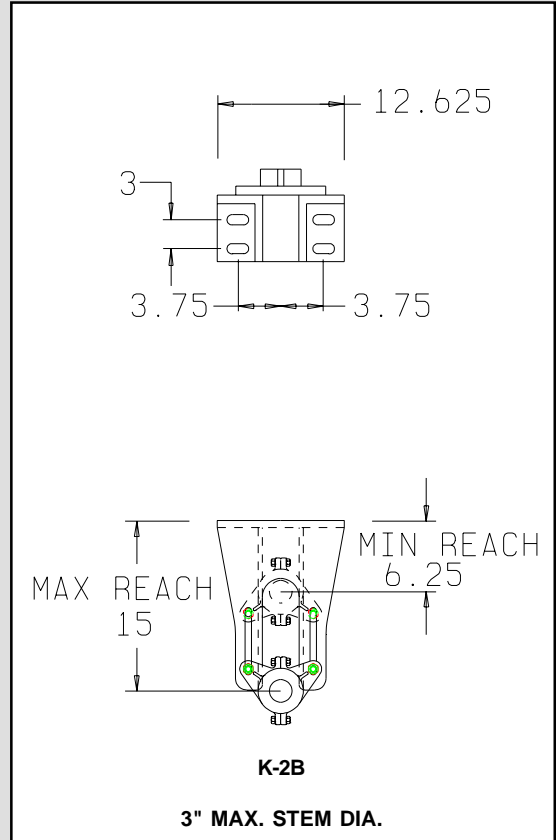
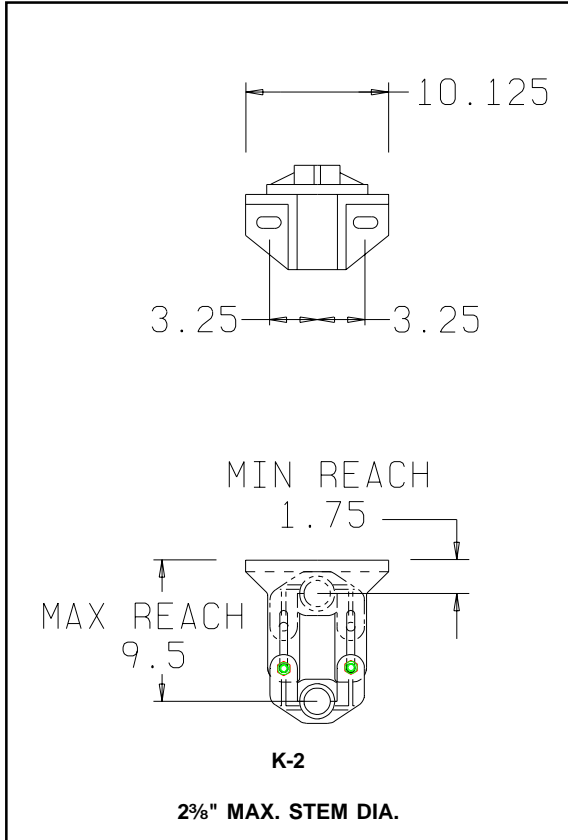

**WATERMAN STEM GUIDES  
TYPICAL DIMENSIONS**

